

**Flow measurement with sensors ZS25
at working temperatures up to +500 °C
optional with integrated and configurable transducer UFA**



Measurable variable

- standard flow velocity v [m/s] in air/gases

Measuring range

- 0.4 ... 120 m/s

Functional principle

- vane wheel flow sensor
- scanning the vane rotation; non-contact inductive proximity switch

Design

- insertion probe with AS80 housing

Medium

- air, gas mixtures and clean gases

Advantages

- low starting value
- large measuring range span
- maximum fatigue strength thanks to vane wheel which is easy on the bearings
- corrosion resistant
- sterilisable
- high working temperature and pressure ranges
- operates to a large extent irrespective of density and composition of the gas
- low pressure drop
- easy adjustment to process parameter

Range and examples of application

- flow rate measuring, e.g. of air, exhaust gas, process gas
- monitoring laminar flow
- monitoring flow in pharmaceutical works

Humidity in the gas

- relative gas humidity of less than 100 % does not affect the measurement uncertainty

Model designation (example)

ZS25/25	-350	G	E	350	p10	ZG4
(1)	(2)	(3)	(4)	(5)	(6)	(7)

Basic types

Type	Transducer/ Output	Article No.
'100 °C' / integrated UFA		
ZS25/25- 250 GE/100/p10/ZG4	UFA-int / 4-20 mA	b002/190-ufa
ZS25/25- 350 GE/100/p10/ZG4	UFA-int / 4-20 mA	b002/191-ufa
ZS25/25- 450 GE/100/p10/ZG4	UFA-int / 4-20 mA	b002/192-ufa
ZS25/25- 550 GE/100/p10/ZG4	UFA-int / 4-20 mA	b002/193-ufa
ZS25/25- 650 GE/100/p10/ZG4	UFA-int / 4-20 mA	b002/194-ufa
'100 °C' / separate evaluation unit		
ZS25/25- 250 GE/100/p10/ZG4	sep. eval. unit / v/FA	b002/190
ZS25/25- 350 GE/100/p10/ZG4	sep. eval. unit / v/FA	b002/191
ZS25/25- 450 GE/100/p10/ZG4	sep. eval. unit / v/FA	b002/192
ZS25/25- 550 GE/100/p10/ZG4	sep. eval. unit / v/FA	b002/193
ZS25/25- 650 GE/100/p10/ZG4	sep. eval. unit / v/FA	b002/194

(1) Sensor type / Sensor diameter

Vane wheel flow sensor ZS25 with sensor Ø 25 mm and shaft Ø 25 mm

(2) Sensor length dimension C (see Drawing 4, Page 1)

250 / 350 / 450 / 550 / 650 mm

(3) Medium

... G ...	air / gases
-----------	-------------

(4) Materials in contact with the medium

Design	Material
... E ...	stainless steel 1.4404 / AISI 316L, ceramics Al ₂ O ₃ 99.9 %
'100 °C' and '260 °C'	PTFE seal
'370 °C' and '500 °C'	pure graphite seal

(5) Permissible temperature of the medium

Design	Temperature of the medium
... 100 ...	-20 ... +100 °C (continuous)
... 260 ...	-40 ... +260 °C (continuous) -40 ... +300 °C (short-time)
... 370 ...	-40 ... +370 °C (continuous) -40 ... +400 °C (short-time)
... 500 ...	-40 ... +500 °C (continuous) -40 ... +550 °C (short-time)

ambience	-40 ... +80 °C	with separate evaluation unit
	-40 ... +80 °C	with integrated transducer UFA-int
	-5 ... +50 °C	with optional 'LCD display'

(6) Max. working pressure / Type of protection for sensor

up to 10 bar / 1 MPa kPa above atmospheric

protection class IP68

(7) Design

as in Drawing 4 (Page 1)

dimensions	A Ø 25 mm	B 13.9 mm	C 250/350/450/550/650 mm
	D 60 mm	E 80 mm	F 130 mm

Measurement range (with a gas density of approx. 1.2 kg/m³) / vane wheel type

Measurement range	Vane wheel type	Art. No.
0.4 ... 20 m/s	mn 20 E	v_mn20GE
0.5 ... 40 m/s	mn 40 E	v_mn40GE
1.0 ... 80 m/s	mn 80 E	v_mn80GE
1.4 ... 120 m/s	mn 120 E	v_mn120GE

measurement uncertainty	< 1.5 % of measured value + 0.5 % of terminal value
-------------------------	-----------------------------------------------------

repeatability	±(0.05 % of terminal value + 0.02 m/s)
---------------	----------------------------------------

Connection housing AS80

dimensions	80 / 80 / 60 mm (L / W / H)
connection	connector GO 070 with terminal screws
terminal assignment	see Page 6
protection class	IP65

Output / transducer (see Pages 2 & 3, 'Basic types')

output 4-20 mA / integrated UFA	UFA integrated in the housing (see Page 6)
output sensor v/FA / separate evaluation unit necessary	Höntzsch evaluation unit with v/FA input necessary for signal evaluation
output sensor v/FA-Ex, sensor with option 'Ex' for use in Category 2G (Zone1) / sep. eval. unit necessary	Höntzsch evaluation unit with intrinsically safe v/FA-Ex signal input or with v/FA input in conjunction with a series connected isolation/supply unit necessary for signal evaluation

Accessories

	Description	Article no.
calibration certificate v/FA		klbneu
standard calibration value depending on vane wheel type, others see Data Sheet U183	mn 20 E: 1; 2; 5; 10; 15; 20 m/s mn 40 E: 1; 2; 5; 10; 20; 30 m/s mn 80 E: 1; 5; 10; 20; 40; 60 m/s mn120 E: 1; 5; 10; 20; 40; 60 m/s	
probe guide piece SFK 25 E-100 / G 2" ZG2 with clamping yoke as in drawing 2	for any repeated positioning even with higher excess pressure (max. 10 bar/1 MPa) / low pressure, through hole 25 mm, connection by screw thread sleeve or ball valve inside thread G 2", working temp. range -20 ... +240 °C, installation length 100 mm, materials: stainless steel, VITON® lip-seal, incl. hook spanner and hexagon screw driver	b004/210

Transducer UFA-int, integrated in the sensor connection housing

analog output/resistance	4 ... 20 mA = 0 ... ____ m/s, resistance max. 400 Ohm
output 'limit value' or 'quantity pulse'	Open Collector / max. 50 mA / max. 27 V DC, pulse duration 0.5 s
PC interface	RS232
self-monitoring	output signals electrically isolated from the power supply parameter settings, sensor interface; in case of error: analog output less than 3.6 mA
connection	connector GO 070 with terminal screws
power supply	24 V DC (20 ... 27 V DC)
power consumption	less than 3 W
working temp. range	-40 ... +80 °C
housing	sensor connection housing AS80
EMC	EN 61 000-6-2
setting parameter	analog output, profile factor/coefficient, pipe inside diameter, time constant, sensor type, measurement range, medium, limit value or quantity pulse (valency adjustable), switching actual/standard flow with setting parameters, 'actual pressure' and 'actual temperature' ...
setting parameter with PC software UCOM and programming adapter (see below) changeable	

Accessories (cont.) / options

	Description	Art. No.
LCD display in housing cover	2 x 16 digit, numerals 3 mm high, working temperature range -5...+50 °C	a010/007
PC software UCOM	for configuring the UFA/int via RS232	a010/052
programming adapter G0 070 / RS232	for software UCOM, connection PC Sub-D 9-pin, power plug 230VAC/24VDC	a010/004
interface converter USB / RS232	PC connection : USB plug type A on instrument : Sub-D 9-pin	a010/100



optional LCD display in the housing cover

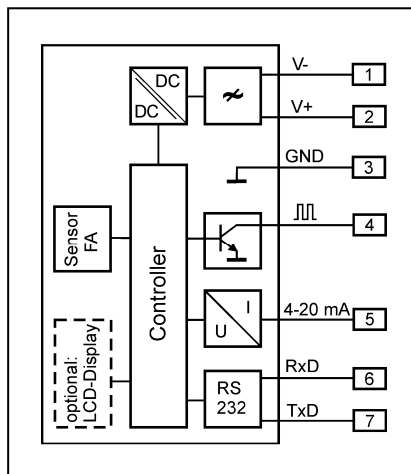

Wiring diagram with integrated UFA

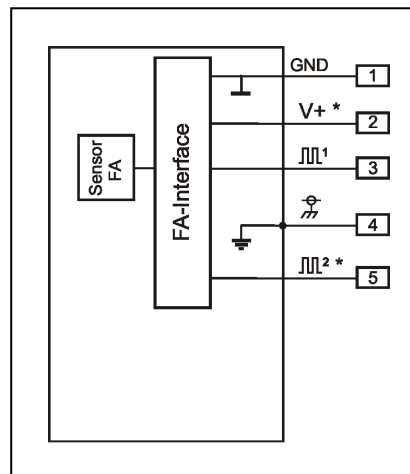

Wiring diagram sensor for separate evaluation unit (* optional)